



Type: Rectangular Grill Stone Hearth Oven

Model: RGO1250

The Beech RGO1250 Stone Hearth Oven is manufactured from a high grade castable ceramic material and completely enclosed in a housing of 5mm mild steel. This mild steel outer casing and incorporated lifting hooks make installation easy which reduces potential damage to the oven. The inside measurements of the oven are 1250mm x 850mm with a 0.69m² cooking surface (0.61m² for full gas). This style of oven can be fired using wood, gas back-up or full gas. The oven is fitted with a slide out grill plate which has two (2) 25Mj ribbon burners with cast iron radiant plates below. The Char Grill is located inside the oven cavity giving double cooking power to grill food in minutes.

The spectacular performance of a Beech Oven is a result of the huge thermal mass of the unique ceramic cast interior. Beech Ovens have **TWICE** the mass (*thermal mass*) of any other pre-cast oven on the market. The unique oven design results in superior cooking performance and exceptional thermal efficiency.

The cooking surface of the oven (*stone hearth*) is constructed using high quality 75mm thick Fire bricks, renowned for their excellent cooking attributes and incredible wear resistance. The use of bricks eliminates the unsightly cracking associated with one piece floors. The bricks sit upon a 25mm VF insulating board and a further 5mm reinforced mild steel base.

The unique three (3) piece oven design allows all Beech Ovens to be installed through a standard 700mm doorway. All Beech Ovens can be installed without the use of a crane therefore significantly reducing the costs of installation. The oven body comes with an exclusive 4 year guarantee.

The oven can be installed within 75mm (*including 50mm of insulating wool and 25mm air gap*) of non-combustible material (*check local building and fire codes*). The oven exhausts through a spigot above the oven mouth. The oven must be vented in accordance with local and/or national codes. Refer to "Duct Design Options" on the following pages or for more information, refer to the Installation and Operation Manual located on our website www.beechovens.com. Allow 400mm sq ventilation into the underside of the oven for secondary air to the gas burner (*if applicable*).

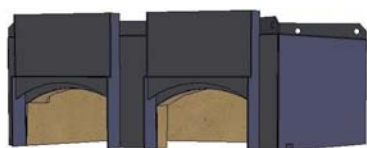

← Upper Section

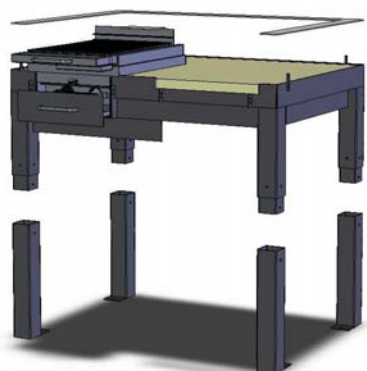

← Base Section

← Legs

Unique Features

Custom features: Wood or thermostatically controlled gas system.
Easy installation into most areas (*three (3) piece assembly*).
Stainless steel plug door for oven mouth.
Any gas type – Specify at order time.

Optional Accessories

- Internal spotlight.
- Viewing window available in any location.
- Various shape/design facades and Stainless Steel Hearths.
- Thermostatically controlled Display burner.
- Exhaust fan.
- Flue transitions, Spray filters, Canopy hoods and fluing options (*See "Ducting Design Options"*).

Approximate Pizza Capacity Per Hour

At 250°C floor temperature the oven will cook:

Size	200mm (8")	250mm (10")	300mm (12")	400mm (16")
Pizza / hour	70	35	25	10

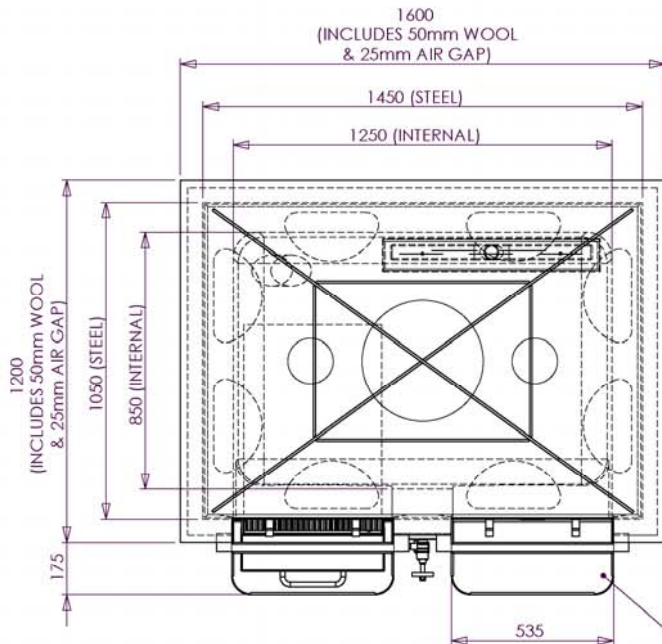

BURNER POSITIONS

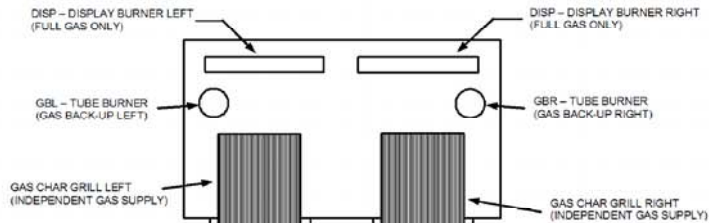

For detailed information on burner positions and configurations, refer to "Gas Systems Overview" document or visit Beech Ovens website www.beechovens.com

GAS TYPES

LPG - NATURAL GAS - TOWN GAS.



OVEN EXHAUST SPIGOT

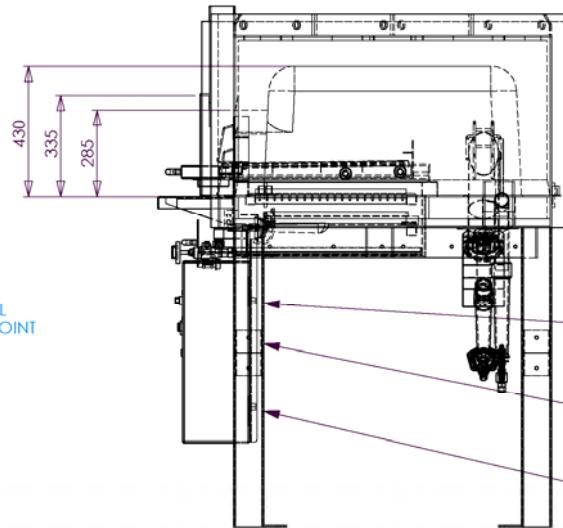
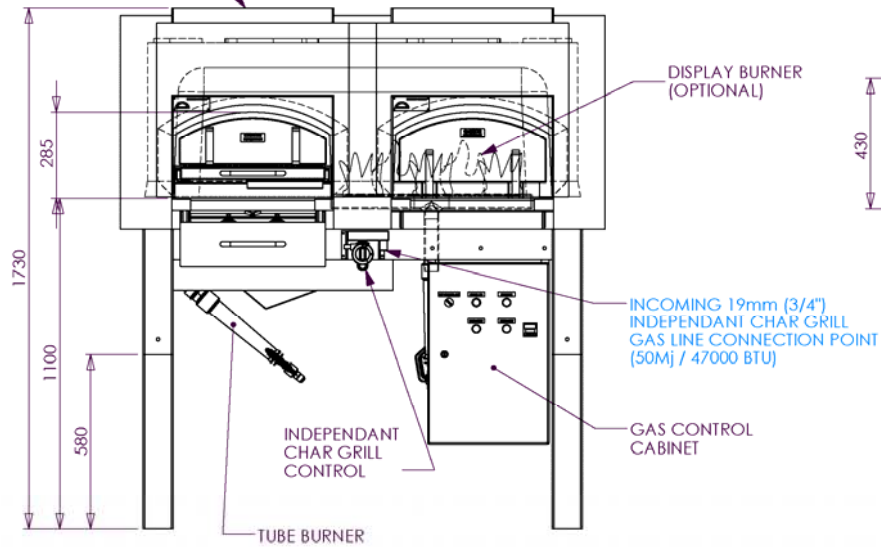

NOTES:

CONNECTION TO APPROVED FLUE/DUCTING REQUIRED (CHECK LOCAL CODES AND REGULATIONS)

THE OVEN IS DELIVERED IN THREE (3) SECTIONS:
 UPPER SECTION - Approx 850kg
 BASE SECTION - Approx 480kg (INCLUDING GRILL)
 LEGS - Approx 10kg EACH

TOTAL WEIGHT = Approx 1600kg

FOR INSTALLATION INSTRUCTIONS SEE INSTALLATION AND OPERATION MANUAL

REV.	DESCRIPTION OF CHANGES	DATE	CHANGED BY
0	ISSUED FOR CONSTRUCTION		

LAST EDITED: Monday, 18 February 2008 11:40:31 AM

©Copyright 2006 Beech Ovens Pty Ltd. All rights reserved.



Drawn S Trood Checked Scale 1:17 Date 18/02/2008

RECTANGULAR GRILL OVEN
 GBL - GRILL/TUBE BURNER LEFT
 SH

A3
 NTS - SITE MEASURE

RG01250-2010 - DETAILS